



KRAL Screw Pumps.
K Series.

Pumps

KRAL Screw Pumps K Series.

The universal KRAL pump with innovative design for long service life, even in harsh operating conditions.



Areas of application.

KRAL K series are screw pumps for lubricating, non-abrasive and chemically inert liquids. They are used primarily in industrial applications, such as:

- Marine, as feed and circulation pumps for fuels and lubricants.
- Mechanical engineering, as lubricant and coolant pumps for gears, engines, turbines and hydraulic systems.
- Oil burner technology, as ring line and transfer pumps.
- Plastics processing, especially polyurethane applications.
- Filling pumps in tank installations, for example: fuel tank, PUR tank or ink tank installations.



How the K pump fits into the KRAL product program.

The KRAL K series screw pump is designed for universal use. It is therefore the best-selling KRAL pump. The K series has a delivery pressure of 16 bar, the casing is made of nodular cast iron and is approved for use on-board ship. It has a sealed, lifetime-lubricated external bearing. The external bearing is not exposed to the pumped medium and is maintenance-free.

The K series is available with DIN flanges in an inline configuration, and the KFT series is available with DIN flanges at the top. Various installation methods are possible for flange-mounting, pedestal and base pumps.

Operation, materials and accessories.

Delivery rates K:	5 to 2,900 l/min.
Delivery rates KFT:	5 to 420 l/min.
Max. discharge pressure:	16 bar.
Temperature range:	-20 °C to 180 °C, magnetic coupling to 300 °C.
Casing:	EN-GJS-400.
Spindles:	Steel, nitration-hardened.
Accepted by:	ABS, BV, CCS, DNV, GL, LRS, MRS, NK, RINA.
ATEX:	Group II, Category 2 ⊠ II 2 GD b/c.
Heating:	Electric, media and steam heating.



Advantages of screw pumps.

Compared to other types of pumps, KRAL screw pumps offer high capacity without taking up much space. This applies in particular at high differential pressure. The pumps are self-priming, with low pulsation delivery and can be easily regulated. The single pumps, single stations and double stations are extremely compact. All K pumps have an internal safety valve.

Stop coupling damage.

With some liquids, residue can build up, which may cause the pump to fail.

A typical spot for residue to build up is at the mechanical seal. The residue damages the ball bearing, which runs hot, melts the elastomeric ring and damages the coupling.

With the K series, there is a weep hole next to the mechanical seal, to prevent the liquid from collecting and building up as residue.

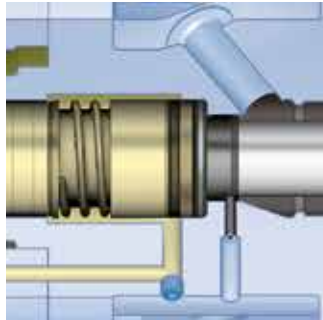
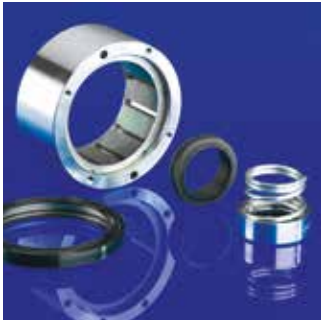

Different types of seal.

As standard the K series is equipped with a mechanical seal. The optional high-quality SiC mechanical seal can be used at temperatures up to 180 °C. A small leakage flow is required to lubricate the friction faces properly.

If the pump is going to be operated at temperatures up to 300 °C or requires hermetic sealing, then the correct choice is the KRAL magnetic coupling. The liquid cannot escape or react by coming into contact with other materials.

Rotary shaft lip seals can be used for clean pumped media up to 6 bar.

Safety backup for dry running.

The startup phase of a pump is critical.

If the pump is not properly filled with liquid and vented, it may take some time for the mechanical seal to be immersed in the liquid. If the seal runs dry, it will not take long to reach temperatures in excess of 200 °C. The O-rings and the seal faces will become damaged, resulting in leakage.

KRAL provides high-quality SiC mechanical seals with graphite, which acts as a dry lubricant. The chemically stable O-rings have a high fluorine content and are suitable for use at higher temperatures. These high-quality components offer additional safety.

Low-viscosity media.

Low-viscosity media can damage the pump due to insufficient lubrication. Abrasive media and solid matter can lead to wear and blockages.

When required, KRAL can provide the pump casing with a special surface treatment. This will improve the frictional properties of the spindles in the casing. The increased hardness provided reduces wear.

This will allow liquids with viscosities as low as 2 mm²/s to be pumped. This also gives a greater safety margin should an unplanned increase in temperature reduce the viscosity.

Low-maintenance operation.

When operated correctly, the KRAL K series pump is low-maintenance.

The lifetime-lubricated external ball bearing is designed for a service life of 30,000 hours. There are two safeguards in place to protect the bearing:

- There is a weep hole just between the shaft seal and the bearing.
- The bearing is enclosed.

The ball bearing is not exposed to the liquid and therefore will not be damaged.

The mechanical seal is bathed by the liquid and is thus well lubricated and cooled. It is fitted in such a way that the frictional heat is guaranteed to be dissipated.

■■■■■■■■ Pumps

Innovative Solutions.

An overview of the technological advantages.

■ Efficiency.

In comparison to other types of pumps, KRAL screw pumps offer a high delivery rate but don't take up a lot of space. KRAL pumps are low in pulsation and run quiet.

■ Short construction.

The K series is known for its short construction. This compact pump is designed for delivery pressures up to 16 bar.

■ Wear reducing surface treatment.

A special heat treatment of the pump housing minimizes friction and wear.

■ Venting the seal chamber.

The seal chamber has a separate vent hole. This allows the pump to be vented easily and correctly during startup.

■ Optimal cooling and lubrication.

The application specific design of the balancing cylinder ensures proper cooling and lubrication of the sealing surfaces of the mechanical seals.

■ Self-purging.

Venting between the positive pressure side and the negative pressure side directly depends on the mechanical seal. In this way, it's ensured that the air buffer through the medium in the vent line can be eliminated, even for vertical installation.

■ Optimized flange construction.

Flanges are constructed according to ISO 3019. This means that KRAL pumps can be connected to common pump mounts. The type of construction used minimizes the size for an optional magnetic coupling.

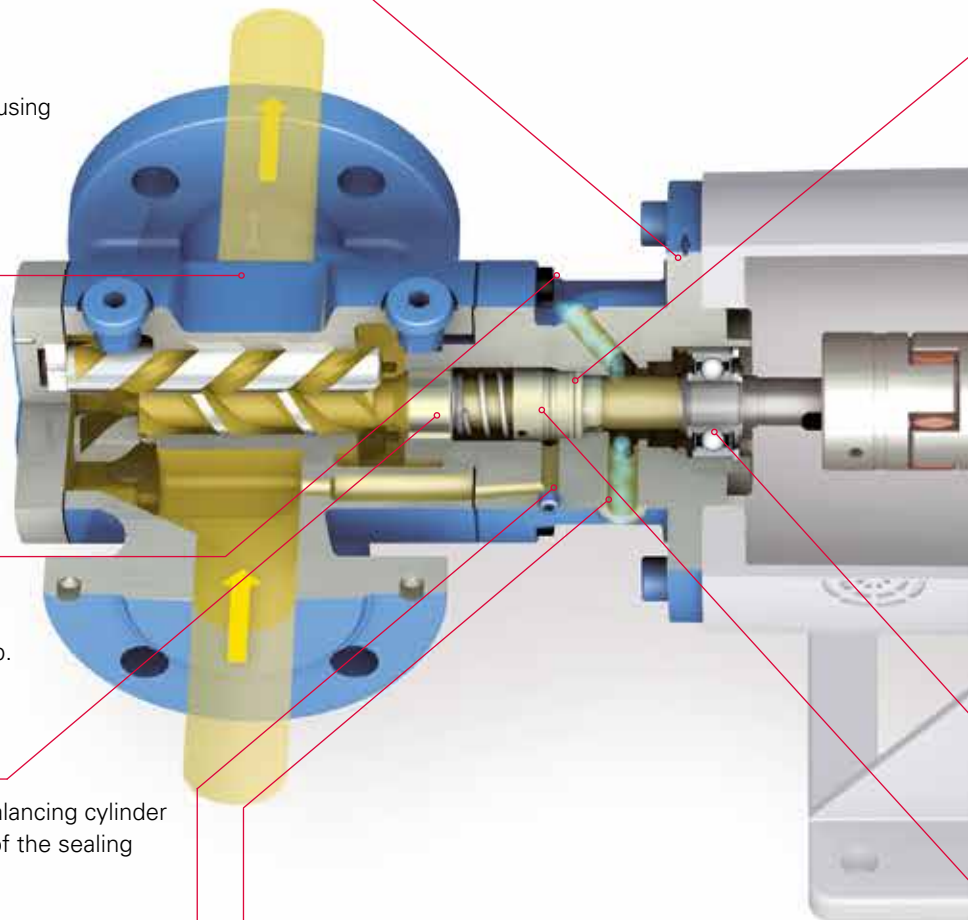

■ No accumulation of residue.

Leakage from the mechanical seals is directly diverted from the stationary seal ring via a vent hold. There is no unnoticed accumulation of residue that might damage the bearings

■ Top quality SiC development.

The highly developed SiC quality of our mechanical seals contains graphite as a dry lubricant. This reduces damaging friction during dry operation.

■ Standard seals.

Depending on the requirements of the application, various types of mechanical seals are available that conform to DIN 24960.

■ Optional seals.

Standard seals are available with various qualities. Options include magnetic couplings, radial seal rings and mechanical seals with fluid (quench type).

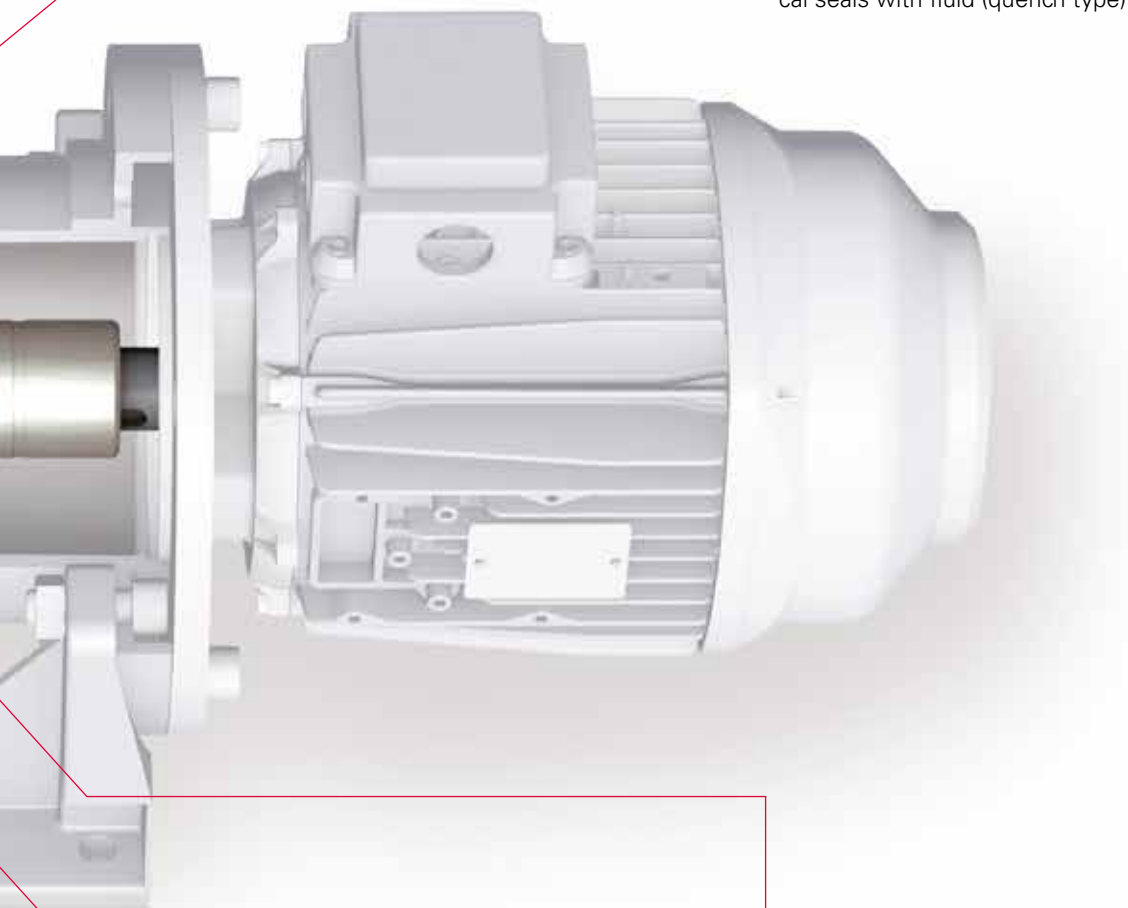

■ Durable O-rings.

High quality O-rings are chemically stable and can withstand high temperatures of up to 180 °C.

■ High quality bearings.

KRAL pumps are equipped with lifetime lubricated and sealed bearings. This increases the lifespan and reduces maintenance costs.

Seal Types.

Seal qualities to meet every demand.

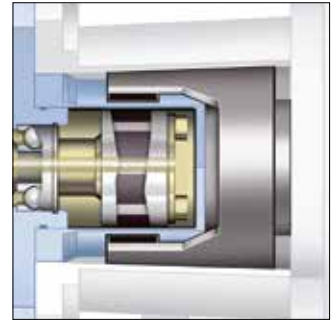
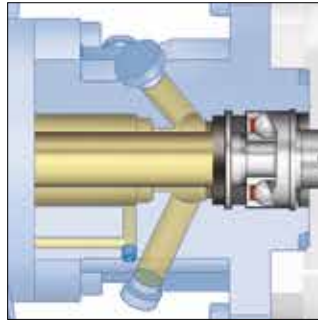
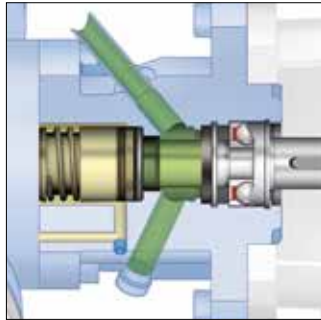
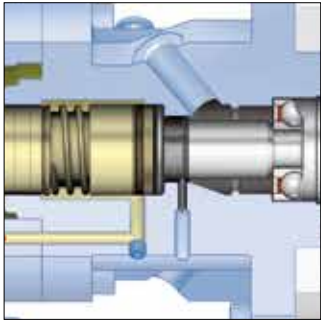

Mechanical seals.

- Standard: DIN 24960, materials as requested, uni-directional, liquids without abrasive content, inlet pressure = 6 bar, $T_{max} = 150\text{ °C}$, viscosity $< 500\text{ mm}^2/\text{s}$.
- Hard material, e.g. SiC, DIN 24960, materials as requested, bi-directional, liquids with abrasive content, inlet pressure = 6 bar, $T_{max} = 180\text{ °C}$, viscosity even above $500\text{ mm}^2/\text{s}$.
- Balanced: DIN 24960, materials as requested, bi-directional, liquids with / without abrasive content, inlet pressure = 16 bar, $T_{max} = 150\text{ °C}$.

Mechanical seal with flushing (quench).

- DIN 24960, materials and version as requested, liquids with a tendency to harden/reaction when in contact with surrounding air, inlet pressure = 6 bar, $T_{max} = 150\text{ °C}$.

Rotary shaft lip seals.

- Standard: Domsel type AC, NBR, liquids without abrasive content, inlet pressure = 6 bar, $T_{max} = 80\text{ °C}$.
- High temperature: Domsel type AC, FKM, liquids without abrasive content, inlet pressure = 6 bar, $T_{max} = 150\text{ °C}$.

Magnetic coupling.

- Standard: Containment can 1.4301, FKM secondary sealing, inlet pressure = 16 bar, $T_{max} = 180\text{ °C}$.
- High temperature: Containment can 1.4301, secondary sealing on request, inlet pressure = 16 bar, $T_{max} = 300\text{ °C}$.

Models.

Numerous installation methods are possible with different KRAL pump models.

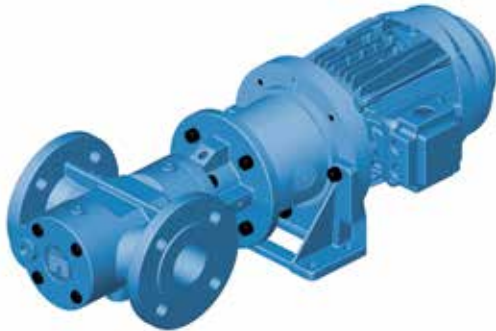

KF flange pump.

The KF flange pump is the universal pump for horizontal installation. Other mounting positions are also possible.

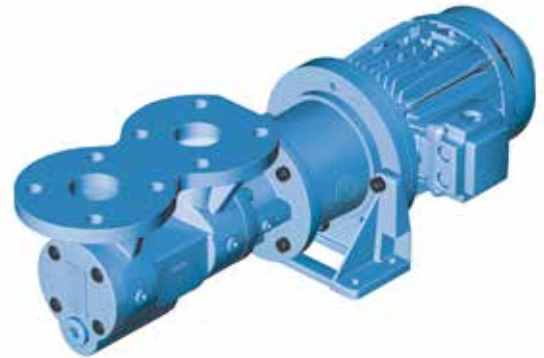

KFT pumps with DIN flanges at the top.

The pump with PN16 DIN flanges at the top for horizontal installation.



KV pedestal pump.

The pedestal pump is the correct choice if there is minimal room at the installation location or if a large, heavy pump is required. Its compact design makes the KV ideally suited for station use.



KVT pedestal pumps with DIN flanges at the top.

This space-saving, vertical installation pump is also available with top flanges.

■■■■■■■ Pumps

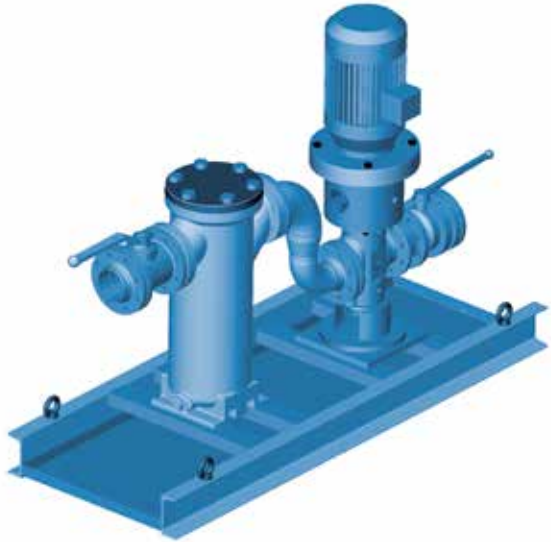

EKL, EKS single station.

KRAL takes on system responsibility with single and double stations. They define the function and the pipe-work connections. KRAL provides single stations for light and heavy oils.

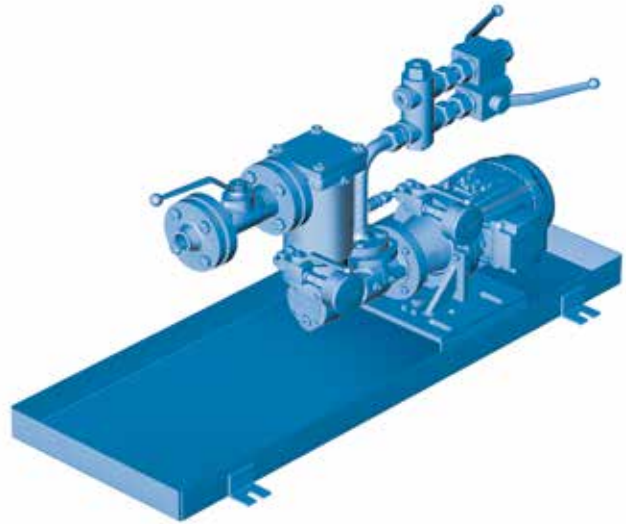

EKL, EKS single station 11, 12, 13.

Oil burner pump station is available in the standards 11, 12 and 13. Version 11 is the basic module. Model 12 has an additional pressure regulator. Model 13 with an additional pressure regulator and a gas / air separator with integrated commissioning filter.

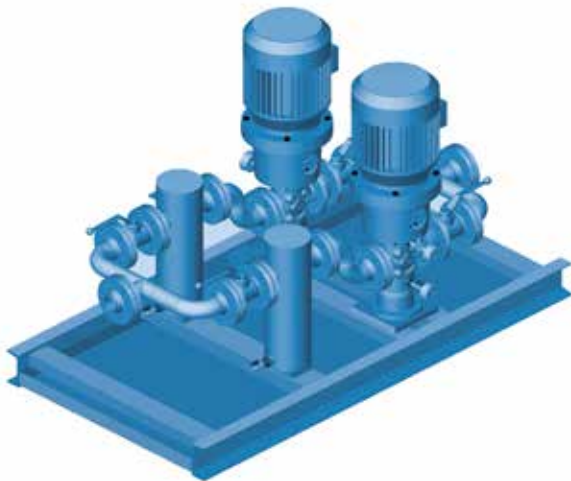

DKL, DKS double station.

Double stations provide greater safety. The second pump is normally used as a back-up or capacity is split between the two pumps. Then, if one of the pumps is damaged, the system can still operate at half load.

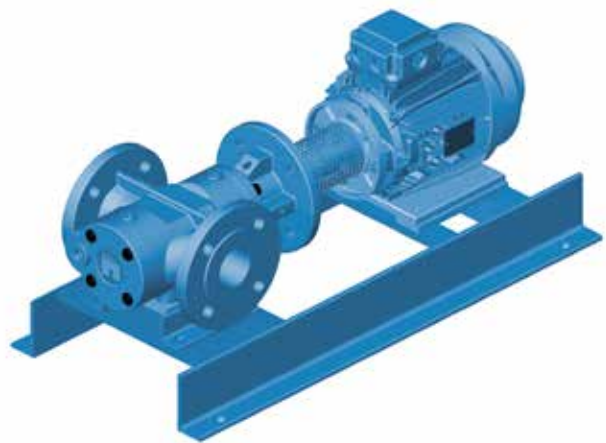

KH base pump.

We also deliver heavy pumps mounted horizontal on a base frame.

Practical Examples.

KRAL applications.



Discharge and transfer-pumps for PUR raw materials.

Pump: KF 20 to KF 550.
 Medium: Polyol, isocyanate.
 Delivery rate: 282 l/min.
 Speed: 750 min⁻¹.
 Pressure: 10 bar.
 Temperature: Ambient.
 Viscosity: Polyol to 5,000 mm²/s, isocyanate to 1,500 mm²/s.
 Seal: Magnetic coupling.

A storage tank depot for polyols and isocyanate is used to supply the raw materials for polyurethane production plants.

Transfer pumps for isocyanate are equipped with magnetic couplings. They prevent the isocyanate from coming into contact with the atmosphere and combining with the water to form abrasive urea crystals. Deposits of these solids can cause mechanical seal leakage.



More safety for the Marine.

Medium: Heavy fuel oil (HFO).
 Delivery rate: 50 l/min.
 Pressure: Up to 8 bar.
 Temperature: Up to 190 °C.
 Viscosity: 3 to 760 mm²/s.

Diesel engines are used on board of offshore ships as the power plant and auxiliary engine. KRAL pumps deliver the fuel in the booster module, in this example heavy fuel oil.

Our customer, a large European ship owner with global establishments including the USA, has upgraded with the KRAL AG. For this upgrade pumps with mechanical seals have been changed to KRAL pumps with magnetic coupling. The reason for this upgrade was, to avoid the normal leakage of a mechanical seal. The leakage evident from lubricating the sealing faces can be a high fire risk. A magnetic coupling is hermetically sealed and leakage free.



Lubricating pump series.

Pump: KF 951.
 Medium: Lubricating oil ISO VG320.
 Delivery rate: 950 l/min.
 Pressure: 10 bar.
 Temperature: 40 °C.
 Viscosity: 320 mm²/s.
 Seal: EAVGG mechanical seal.

A typical customer is a steel works manufacturer. In such an application KRAL pumps deliver the lubricating oil for the rolling contact bearings of the mill trains.

Because of the harsh operating conditions, it is absolutely essential for the pumps to be robust. KRAL KF pumps have a castmetal casing. The pump is very compact, as it is designed for inline use. This means that the installation does not take up excessive room in the mill train.



Photo: Krauss-Maffei Kunststofftechnik GmbH.

Component producer.

Pump type: KF 118.DCA.
 Delivery rate: 20 to 110 l/min.
 Pressure: Up to 15 bar.
 Temperature: Up to 190 °C.
 Viscosity: 300 to 5,000 mm²/s.

Mattresses and car seats are made from flexible PUR foams, refrigerator insulation and facade elements from rigid PUR foam. The preparation and precise batching of the liquid components are crucial criteria for component quality and process stability. In special applications, the polyol components can be highly viscous.

KRAL screw pumps work very precisely and reliably. For end-product customers, this means outstanding product quality and high plant availability, even if the materials used are highly viscous.

■■■■■■■ Pumps



Engine room booster module and separator pumps on-board ship.

Pump: KF 74.
Medium: HFO, MDO.
Delivery rate: 20 to 74 l/min.
Pressure: 8 bar.
Temperature: 160 °C.
Viscosity: 2 to 1,000 mm²/s.
Seal: Magnetic coupling.

In large-scale diesel engines the pressure and the viscosity are set in the booster module. Heavy fuel oils are pre-heated up to 160 °C. This temperature can damage the mechanical seals. When the fuel comes into contact with the atmosphere, residue may form which could destroy the ball bearing. As a result, the pumps could fail and the diesel engine would cut out. The ship would be unable to maneuver.

The magnetic coupling is hermetically sealed and can be operated at up to 300 °C.



Oil pumping stations for motor-driven power plants.

Pump: 2 x K 660 in a double station.
Medium: HFO.
Speed: 1,750 min⁻¹.
Pressure: 5 bar.
Temperature: 50 °C.
Viscosity: 380 mm²/s.
Seal: SiC mechanical seal.

Power plant constructors and energy suppliers are under constant pressure to deliver the required energy supply. KRAL stations supply the booster modules in fixed or floating diesel-driven power plants with fuel for the motor.

KRAL stations pump heavy oil from the day tanks to the booster modules, where the fuel is conditioned before delivery to the motor's injection pump.



Transfer pumps on support ships.

Pump: KFT 32 - 74.
Medium: Fuel oil, lubricating oil, hydraulic oil.
Delivery rate: 70 l/min.
Speed: 3,400 min⁻¹.
Pressure: 2 bar.
Viscosity: 25 to 1,000 mm²/s.
Seal: Radial shaft lip seal.
Acceptance: DNV.

Support ships transport all the requisite materials to oil rigs and return with the waste. To run the support ship, the fuel and lubricants, as well as the hydraulic oil, are pumped from the storage tank to the day tank. KRAL transfer pumps provide the daily quantities of fuel, lubricating oil and hydraulic oil.

KRAL KFT pumps can be certified by the Acceptance Authorities.



Joint projects.

Our business partners are particularly appreciative of the cooperative collaboration with the KRAL AG. From the best possible support to the successful conclusion of the project, friendly business relations are always the order of the day. We take the time to talk to our customers and collaborate closely with them on technical matters. You can rely on KRAL.

