



OUR POWER, YOUR SATISFACTION



WOBBLE PUMPS

Industrial pumps

RL / RJL / RFL series



Wobble pumps series

Our range of wobble pumps are the ideal solution for those seeking a highly compact and versatile product. They are particularly easy and economical to maintain, due to the very small number of component parts. They can be used in a variety of industrial applications due to their ability to pump products which are viscous, which have solids in the fluid or which are mildly abrasive. Perfect for those seeking a highly efficient, economical product, these offer an unparalleled cost/benefit advantage. Even at high rpms, they pump without pulsating and there is virtually no centrifugal effect. They are also suitable for use within the food industry, as there are no dead zones within the pump.

The RL series range of pumps all have solidly constructed housings in cast iron and stainless steel (AISI Type 304 and AISI Type 316), manufactured using lost wax casting technology.

Threaded GAS BSP connections are available as standard, but we can also supply DIN 11851 type adaptors upon request.

- The RL Series: a highly compact product due to its integrated construction between pump and electric motor. It uses the patented Diamond Series joint, which guarantees exceptionally high reliability. The lantern between the pump housing and the drive has been removed to offer the benefit of a product which is compact and easy to maintain.



- The RJL Series: this is based on the same technology as the RL Series. However, in contrast, it uses support bearings with free bare shaft. The RJL series can be connected via the flexible coupling and is the ideal solution to supply as a bare shaft pump. The bearings ensure maximum reliability in all operating conditions.



- The RFL Series: this is based on the same technology as the RL Series. However, in contrast, it uses support bearings with a plug-in shaft at the inlet. The RFL Series can be directly connected to the drive via a flange. The ideal solution to supply as a bare shaft pump, while still maintaining a compact size and easy installation. The bearings ensure maximum reliability in all operating conditions.

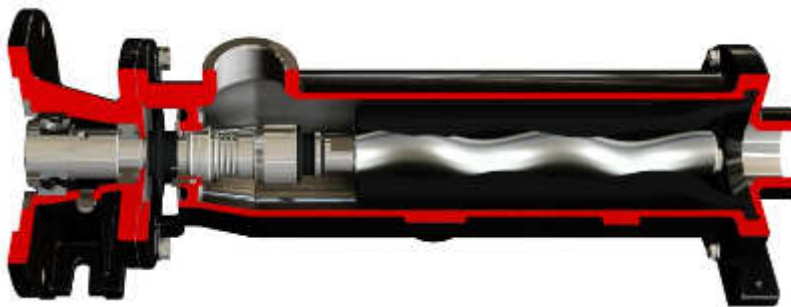

Patented Joint: A pin-type joint, the true heart of the cavity pump, offering the best solution of its type currently available on the market. Superior durability, reliability and maintenance costs, it successfully combines an extremely compact size with incomparable robustness. Its special construction allows the axial loads and torques to be split into different elements, which makes it unique. In addition to this, replacing worn components is inexpensive, due to the added bushings in the areas of wear, which avoids having to replace costly components (rotors, drive shaft and hollow shaft).



Stands: The pump can be installed without a stand. This helps to reduce the overall dimensions and avoids additional costs. When necessary, stands, customised skids and trolleys can be provided, allowing the pump to be moved.

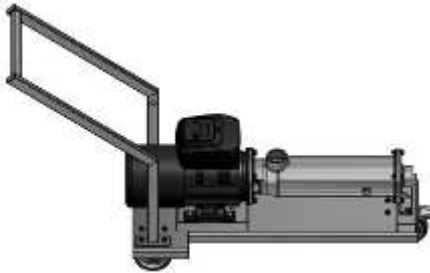

Modular Design: The RL Series is based on a modular concept in every single feature: hydraulic parts, casings, seals, stands, supports and drive shafts. Each component can be constructed in a number of variants without modifying the structure of the machine, thus maintaining standard key replacement components.



Performance: Durability, reliability and low energy consumption. The RL series successfully combines a compact size with high performance in one single product.

Efficiency: The highest possible standards, exceptional operating efficiency due to its excellent volumetric efficiency, even at high pressures, and minimal energy consumption. All the hydraulics on the RL series have been calculated to ensure the best you can find anywhere on the market today.

Materials: The parts of the RL Series pumps which are in contact with the product can be manufactured from different materials, from the cast iron version (GG25) to stainless steel (AISI Type 304 and AISI Type 316). However, the cast iron versions still have the rotating parts made from AISI Type 304 and AISI Type 316 stainless steel.

Low pulsation: Very low pulsation and tensional stress. The centrifugal effect is reduced to a minimum, due to its low operating speed and the predominantly axial pump system.

Shaft seals: The pump uses internal single mechanical seals as standard. The seal is located inside the pump housing. This solution ensures the maximum heat exchange between the surface of the seal and the product being pumped, which gives the benefit of increased durability. Moreover, the position of the seal makes it much easier to keep clean, thus avoiding product residues that could negatively affect operating conditions. The housings are suitable for the installation of seals manufactured in accordance with ISO EN 12756.



Versatility: The RL Series is designed to be versatile in all of its applications, which is why it can be arranged with options and accessories that are suitable for every application. In addition to this, there are the benefits that the special characteristics of a cavity pump can naturally offer in pumping various kinds of fluids, fluids with low to very high viscosity, clean fluids or those containing solids of various types and sizes.

Drives: All the drives installed on the RL Series have been endurance-tested and have been subjected to strict and stringent technical testing. We can install either electrical or hydraulic motors.
All models of electrical motor reducers and variators have certain features in terms of robustness, dimensions of the bearings and quality of the gears.

Quality: Each component is manufactured to very stringent quality specifications. The finishing and the precision of each component are the starting point for every single pump built. All components are subject to specific controls according to their features and their functionality.

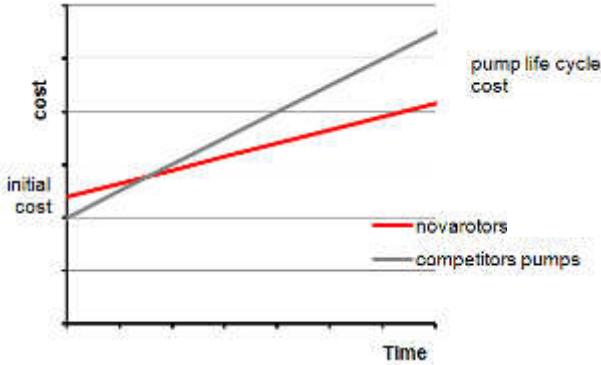

Maintenance: The RL Series is designed to ensure easy maintenance, with only a minimum number of replacement parts necessary.
In particular the bushings on the joint enable it to be completely replaced without having to replace the shafts and rotors. Maintenance costs are thus reduced. The cost of the machine is also highly competitive, considering its entire life-cycle.

Cost / Benefit: Due to the compact size of its components, the RL Series successfully combines incomparable technical features with very competitive costs. Its modular design enables the right solution to be offered for each specific application, which avoids having to pay for any unnecessary features. All of which increases competitiveness.

Priming abilities: The special features of the hydraulic parts of the wobble pump allow excellent priming abilities (up to 4m). The pumps in the RL Series are designed to create the lowest possible pressure drop in the pump housing, due to the wide sections, a compact joint and its fluid dynamic design.

Easy installation: The RL Series pumps are easy to install, due to their compact size, their simplicity of operation and their operational flexibility, and the various fittings available.

Detailed documentation: Each pump comes supplied with clear and detailed operating instructions. All orders are handled by expert, qualified staff who, as part of each order, include detailed and specific documentation for the product supplied.

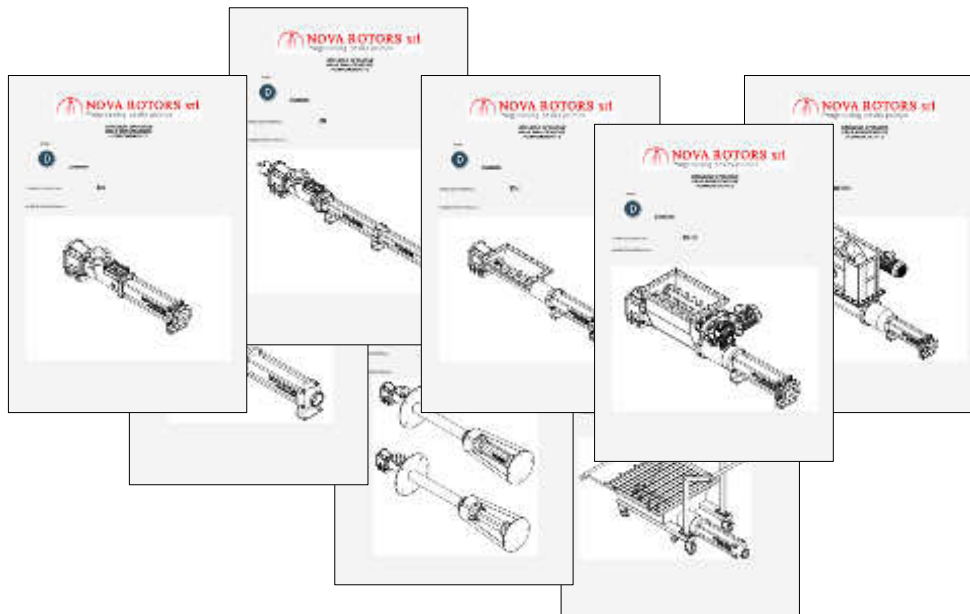

Features in detail

Rotating parts made from stainless steel as standard, even for cast iron pumps. Various metals available, depending on the application. Different options for the drive shaft, according to requirements.

Electric motor integrated into the pump construction. Direct **coupled**.

Outlet sections designed to reduce pressure loss. The pump housing can be manufactured in different metals, according to requirements. GAS BSP and DIN 11851 Connections Available.

Wide suction sections enable excellent priming abilities and the efficient pumping of viscous substances. The threaded inlet port can be coupled, according to requirements. GAS BSP and DIN 11851 Connections Available.

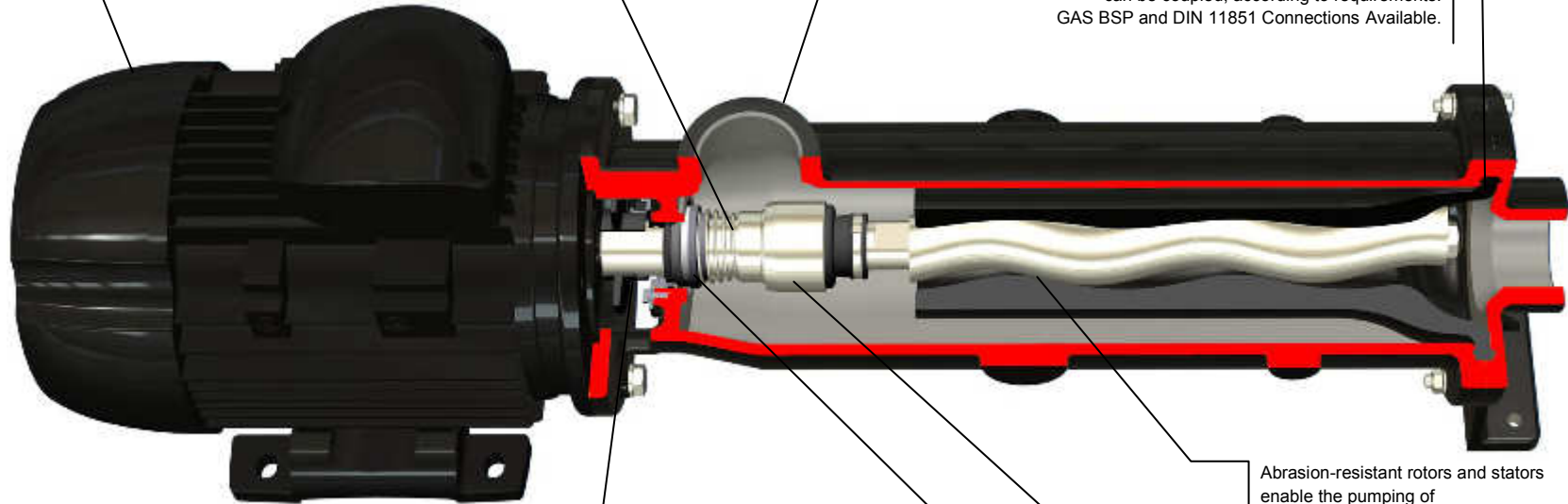

Connection via **plug-in shaft** to the drive or to the **bearing unit**. This is the simplest solution for maintenance. The splash ring protects the drive shaft from corrosion, once again making maintenance easier

Abrasion-resistant rotors and stators enable the pumping of highly viscous fluids and fluids with suspended solids. The rotor can be supplied in different base metals and heat-treated or coated in order to increase durability. The stators can be configured with various types of elastomers.



RJL SERIES

Modular bearing supports
Exceptionally high-performance bearings for maximum reliability.
Free bare shaft for **flexible coupling** with joint or belt-pulleys



RFL SERIES

Modular bearing supports
Exceptionally high-performance bearings for maximum reliability.
Plug-in shaft for direct flange coupling. Ideal for coupling with reducers and variators.

Patented pin-joint, the heart of the RL Series pumps.. It combines a compact size with ease of maintenance, offering

Single mechanical seal inside the pump housing. A conical spring seal is used as standard. Highly reliable and easy to install. Its simple construction enables easy cleaning. It is also possible to install a wide range of ISO EN 12756 standard seals in order to meet any application requirements.

VERSIONS AND OPTIONS

Casing Material

Base materials:

GG25, CF8 (AISI Type 304), CF8M (AISI Type 316)

Shaft seal material

Base materials:

AISI Type 304, AISI Type 316

Rotor materials

Base materials:

AISI Type 304, AISI Type 316

Coatings:

Thick hard chrome coating

Stator materials

Base materials:

NBR, food-grade NBR

EPDM, food-grade EPDM

FPM, food-grade FPM

Stands

Standard base

Base with hygienic, anti-vibration, adjustable feet

Skid with hoisting equipment

Trolley for industrial sector

(For details of construction, please refer to the brochure for options, accessories and fittings)

Connections

Threaded GAS BSP connections

DIN 11851

Seal systems

Single mechanical seal

Protection devices

Flow switch

Pressure switch

Sanitary pressure relief valve

Pressure relief valve with threaded GAS BSP connections

(For details of construction, please refer to the brochure for options, accessories and fittings)

Protection devices

Electrical panel

Electrical panel with inverter

Motor with integrated inverter

(For details of construction, please refer to the brochure for options, accessories and fittings)

Options and fittings

Bypass with threaded connectors

Protective drive casing

(For details of construction, please refer to the brochure for options, accessories and fittings)

Certification

CE

FEATURES OF USE

Operating range

Flow rate

Up to 14.4m³/h

Pressure

Up to 4 bar

Temperature

From -40°C up to 80°C

Typical applications

Sewage sludge

Water treatment

Industrial sludge

Industrial detergents and chemicals

Products from the paper industry

Water treatment

Agriculture

Industrial detergents and chemicals

Products derived from petrochemicals

Marine Industry

SUMMARY TABLE OF THE RANGE

Flow rate and pressures

Size	Nr Poles	Qmax 1 bar [m ³ /h]	rpm	P max [bar]	P inst (KW)
R40L	4	5,5	1410	4	1,5
	6	3,6	915	4	1,1
	8	2,8	700	4	0,55
R80L	4	14,4	1410	3	4
	6	9	950	4	2,2
	8	7	710	4	1,5



Via Carlo Cattaneo, 19/25
36040 - SOSSANO (VI)
ITALY



ISO 9001: 2008
No.:2011/1353



OHSAS 18001:2007
No.:2010/915



CEC 07 ATEX 110 - REV.1